

# ALENIA SHM FIBER OPTIC BRAGG GRATING (FOBG) STRAIN SENSORS TECHNOLOGY: APPLICATIONS AND REQUIREMENTS

F.P. Camerlingo, G. Cavaccini, A. Ciliberto, C. Voto (Alenia Aeronautica); Mario Iodice (CNR - IMM), F. Pezzuti (MARS)

[fcamerlingo@aeronautica.alenia.it](mailto:fcamerlingo@aeronautica.alenia.it)

## STRUCTURAL HEALTH MONITORING (SHM) IN AERONAUTIC FIELD APPLICATION

*In this paper, the description of Alenia SHM technology by means FOBG for aeronautic field application is reported; CNR IMM and MARS are the Italian partners have worked together with Alenia to the technology development in the last years. In comparison with the conventional and already tested sensors and methods, the sensors in optic fibres show several advantages in terms of weight and size reduction, no EMI, measure long duration stability. Between these, the sensors with Bragg grating represent a valid solution, being moreover available in commerce with efficient and a repetitive characteristics. With these sensors, bonding techniques on metallic and composite parts surface are already tested together with FOBG embedding procedure in carbon resin component (Alenia patent). The instrumentation to analyse FOBG signals, are going to be available on commerce in typical configuration for laboratory applications, but are not again suitable for flight application. So, there is the exigency to define and accomplish, starting by off the shelf components and if necessary by custom components developing, a reliable FOBG instrumentation that satisfy airworthiness requirements necessary to an aeronautic application. This instrumentation is defined from the indivisible connection between a dedicated opto-electronic HW configuration and a suitable SW oriented to typical aeronautic exigencies and to data management objectives. In this article the application of sensors on different type of structures, the adopted devices and the future activities for flight tests are described.*

### 1.0 INTRODUCTION

This paper describes the potential possibilities of Fibre Optic Bragg Grating (FOBG) as strain sensors in aerospace applications. These applications are aimed mainly to an higher safety level and structural reliability and a lower maintenance and operative costs of aerospace structures.

This type of sensor can be interrogated with different type of opto-electronic instrumentation on which several research teams are working. Therefore it can be useful to summarise the main applications with relevant requirements, as these information can help in tailoring the instrumentation and sensors development toward the intended application.

The past and current experience allows to affirm that two important FOBG applications can take added values:

- the capability to embed the FOBG in composite structures allows a direct monitoring internal to the material (no possible in metal) with an incomparable advantage in terms of internal crack monitoring and crack propagation;
- The FOBG weight and dimensions characteristics and the possibility to have several sensors, in serie, on a single fibre optic cable, give advantages in terms of easy applications on external side of aircraft and great number of monitoring points.

In this paper, these topics will be treated with a greater depth together with the flight test preparation phase description on a transport military platform.

Camerlingo, F.P.; Cavaccini, G.; Ciliberto, A.; Voto, C.; Iodice, M.; Pezzuti, F. (2006) Alenia SHM Fiber Optic Bragg Grating (FOBG) Strain Sensors Technology: Applications and Requirements. In *Multifunctional Structures / Integration of Sensors and Antennas* (pp. 7-1 – 7-12). Meeting Proceedings RTO-MP-AVT-141, Paper 7. Neuilly-sur-Seine, France: RTO. Available from: <http://www.rto.nato.int/abstracts.asp>.

## 2.0 FOBG SENSORS APPLICATION PROCEDURE ON METALLIC (SURFACE) AND COMPOSITE (SURFACE AND EMBEDDING) MATERIALS

### 2.1 Metallic and composites surface application

The activity developed with the aim to identify the most convenient and efficient FBG surface installation procedure can be summarized describing the subsequent steps to accomplish. In the following we will report the conceptual and practically tested phases finalized to the sensor application step. A fundamental requirement is the definition of the working place conditions, which are:

- Temperature between 10 – 30 °C;
- Relative humidity between 20% and 70%;
- The ambient shall be clean and free from dust.

The operations sequence to bond FOBG sensors on metal and/or composite materials surface is below summarised.

- Surface decontamination and degreasing,
- Mechanical abrading surface,
- Application of sensor layout lines,

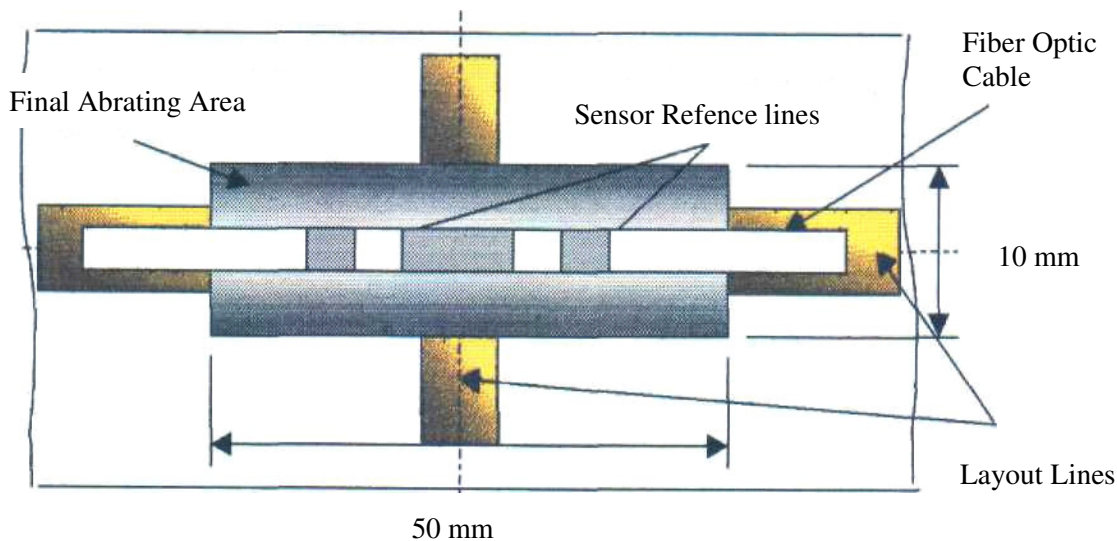

Figure 1 – FOBG application scheme

- Chemical surface preparation,
- Positioning of sensor on specimen,
- Preparation of the adhesive,
- Alignment of the sensor on the specimen,
- Placing of FBG sensor on surface,
- Clamping of sensor and pressure force,
- Temperature cure of sensor,

- Installation checks,
- Protective coatings,
- Fixing of sensor,
- Final protection.

## 2.2 FOBG embedded in composites

The requirements of the FOBG sensors to embed inside the composite multilayer material are:

- resonance wavelength included between 1520 and 1570 nm and reflectivity not less of 90%;
- full wave half height (-3 db) of the reflection spectrum less than 0.20 nm;
- grating sensor length between 6 e 9 mm;
- fibre optic cover in Polyamide, due to the particular temperature/pressure cure conditions, during the embedding process;
- maximum section size where the polyamide or acrylic cover is removed: 2 cm; in this section there is the grating sensor and must be possible to discriminate his position;
- no degradation of the fibre optic in a temperature range between  $-55^{\circ} \div +80^{\circ}\text{C}$ .

### Embedding Procedure

This method can be applied mainly but not exclusively to embed FBG sensors in aeronautic composite structure accomplished with different manufacturing process. For example the carbon-carbon laminate obtained by means polymerisation process in autoclave with a temperature/pressure cycle and the fibre metal laminate are suitable structures to host FOBG's. The application of FOBG requires the embedding between plies not again polymerised. The fibre optic cable can not exit from the composite material through the external edge because the necessary trimming phase. The FOBG embedding inside to composite material components with polymeric matrix is accomplished placing the fibre optic between contiguous plies. After, the handwork is submitted to a suitable polymerisation process by means a temperature/pressure cycle required by the polymeric matrix nature. The fibre optic has to be placed in such a way to avoid breaks in the critical point of the ingress/egress from the component. This can be made by means a small rubber disk bonded on the composite component surface. This procedure, reported below, gives a better guarantee on the FO application respect to the break risks in fact:

- allows the ingress/egress of the FO cable through the handwork surface instead through the component edges, avoiding all the trimming difficulties;
- assure an high strength of the FO in the ingress/egress critical point due to the presence of the small rubber disk that inhibits the blob resin formation and produce an elastic link for the FO in the same points;
- allow easy possibilities to perform following trimming and assembly operations on the components, assuring the FO integrity.

The operations sequence is below reported.

- To cut all the pre-preg material layers in accord to design requirements;

## Alenia SHM Fiber Optic Bragg Grating (FOBG) Strain Sensors Technology: Applications and Requirements

---

- place on and compress the layers to have the two pre-preg packets;
- collocate on the surface, in the ingress/egress points of the fibre optic the rubber disk;
- apply on the surface a separating film layer and perform the compression by means the vacuum bag;
- perforate with hollow needle, in the correspondence of rubber disk, the superior packet leaving the needle in the suitable position and insert the fibre optic in the needle;
- extract the needle and stretch the fibre optic; in this phase in order to avoid fibre breakage due to the operations before, during and after the cure cycle, the following care and cautions are required:
  - during all the handling and embedding phase, avoid to fold the fibre optic with radius lower than 0.25 inches;
  - the length of fibre optic cable (pigtail) out of the composite laminate (out of rubber disk) shall be at least 8-10 inches and rolled itself respecting the previous requirement; hold rolled fibre optic with little pieces of applicable adhesive tape (see figure 2a);
  - to avoid resin bleeding, this rolled fibre optic shall be protected and “packed” between two layers of release f.e.p. film sealed along edges with adhesive tape type “Wrightcast 8500 ps” (see figure 2b);
  - avoid the rolling of fibre optic to the egress from the rubber disk: leave at least 3 cm of straight course after the egress and, hence, start with the rolling of optic fibre to insert in a protection bag; to block the rolling section, use removable adhesive tape on three side of the bag and leave just one free strip in order to give the capability of an easy insertion/removal of the fibre optic cable after the cure;
  - from the open side where the fibre optic pigtail is inserted in the protection bag, spray Frekote material in order to avoid the bonding and the overlap of the fibre optic cable inside the protection bag;
- fix the protective bag including the extremity of the fibre optic cable to the separating film;
- place the packet on the other packet and perform the compression of the two packets by means vacuum bag;
- prepare the final vacuum bag overlapping to the final packet (arising from the union of the packets) a separating film, a ventilation material and a vacuum bag film;
- seal the vacuum bag film on the polymerisation and layering device by means sealant material;
- apply on the vacuum bag the valve for connection to vacuum equipment and inhale the air contained in the bag;
- take this assembly in autoclave and apply the required polymerisation process with pre-defined parameters of temperature pressure etc.;
- at the end of the autoclave phase, extract the assembly, unmake the vacuum bag and trim the handwork along the whole edge;
- remove the protection bag and unchain the fibre optic cable in order to be ready to apply the connector.

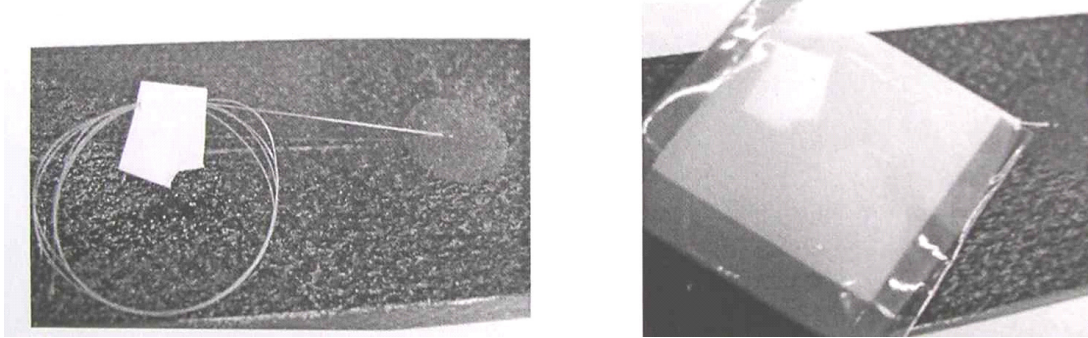

a) Rolled Fibre Optic trough rubber pad      b) Rolled Fibre Optic packed with protective bag

**Figure 2 - FO cable ingress/egress protection**

### 3.0 NEW INSTRUMENTATION CHARACTERISTICS FOR FLIGHT TESTS

The instrumentation for flight test application is constituted of a box schematised in figure 3.

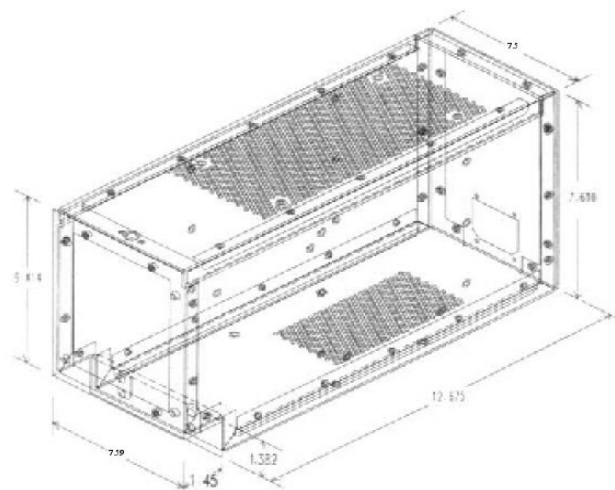

**Figure 3 - External case**

This box includes all the optical chain and two microcontrollers board for the signals analysis and the parameters monitoring. The optical chain is schematised in the figure 4. The main component of the optical chain is an Acousto-Optical Tunable Filter (AOTF) with wavelength 1550 nm; SELEX S.I supplies this component.

## Alenia SHM Fiber Optic Bragg Grating (FOBG) Strain Sensors Technology: Applications and Requirements

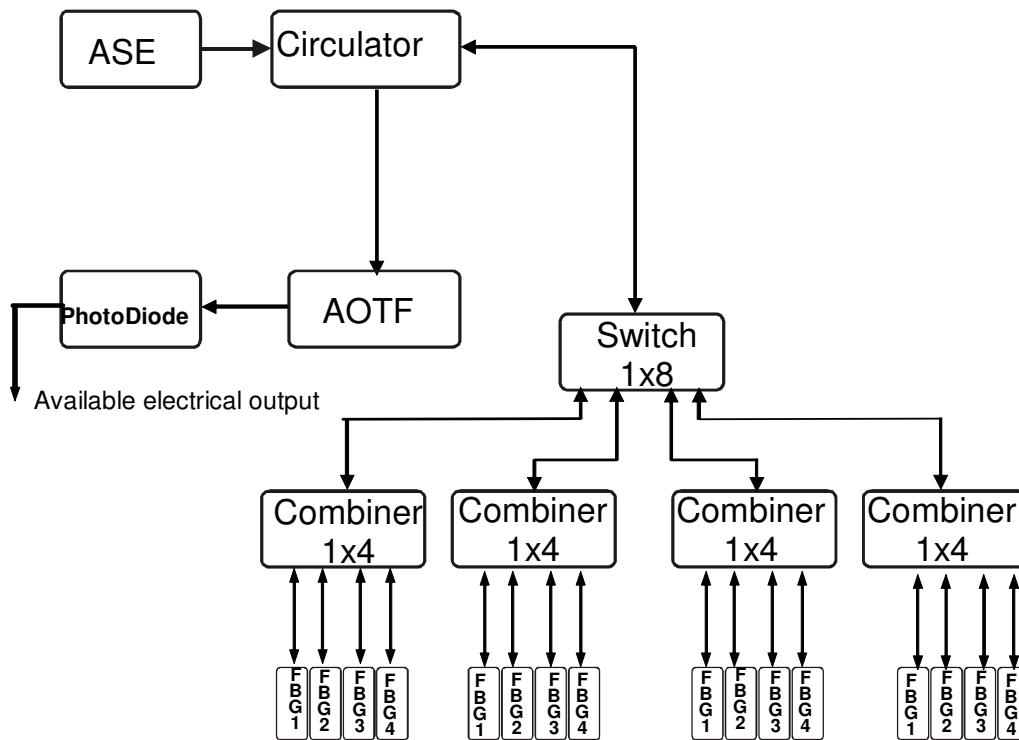

Figure 4 – Optical Chain, based on AOTF approach

## 4.0 FLIGHT TEST

### 4.1 Involved Sensors

The main objective of the flight test plan on a transport military aircraft is the verification of the applicability of the Fibre Optic Bragg Grating (FOBG) sensors technology for airworthiness scopes. The verification method is based on the comparison with the responses of the Strain Gauge (SG) technology already used and qualified.

The typologies of sensors used in this flight tests plan are the following:

- Fibre Optic Bragg Grating (FOBG),
- Strain Gauge (SG), Rosette Strain Gauge (RSG),
- Rosette Fibre Optic (RFOBG).

In addition and in the same area (the closest possible) a FOBG sensors only dedicated to the temperature measurement will be applied in order to discriminate the thermal effects only and remove them via SW from FOBG measurement in same area, in this way two scopes will be reached:

- capability to make a comparison with the conventional strain gage (where the temperature effects are already considered),
- obtain from the FOBG sensors, the mechanical strain usually requested for load and SHM objectives.



## 4.2 SENSORS POSITIONING AND FLIGHT TEST ANALYSIS

The activity concerning the individuation of sensors positioning on the transport military platform referred to his typical flight profile mission, has been already performed.

Two areas have been individuated and are shown in the figure 5.

- AREA A: Panel between frame 14-15 and stringers 10-11 on left side,
- AREA B: Left forward Lower Lug.

For each of the two areas, a single FOBG sensor will be dedicated exclusively to the thermal strain contribution survey. The application procedure and scheme of these types of thermal sensors is shown in the figure 6.

The temperature compensation by means a dedicated FOBG sensor is based on the concept that the grating have not to sense the mechanical strain but only the strain variation due to the component wall temperature change. This is made with the aid (see figure 6) of a capillary steel tube with the following characteristics:

- external thickness: 0.8 mm
- hole diameter: 0.4 mm.

This tube is entirely applied with adhesive paste and protective material (in the area A, an application on the external surface of the aircraft is foreseen) in order to be fixed in optimal way on the component surface (total diameter tube + paste adhesive: 1 mm). Inside this steel tube is inserted a fibre optic cable with the Bragg grating sensor free to float (the thickness of the fibre optic cable is generally between 0.22 ÷ 0.25 mm, depending on the fibre optic cover); only one side of the fibre optic cable (that coming out from the capillary steel tube to be connected to the instrumentation) is bonded, while the other side ends to 20 cm from the boundary of the capillary steel tube and it is free to float; this guarantees the insensibility of the grating sensor to the mechanical strain (felt only to the capillary steel tube) while the thermal effects are felt by the grating.

A calibration of thermal strain measured by the grating, due to the presence of the capillary steel tube external to the FOBG sensors, is performed in order to obtain directly the thermal strain effect due to the component wall temperature variation. This calibration procedure (expressed by means an algorithm) is inserted directly in the instrumentation SW, hence, this procedure allows to have directly from the other FOBG's present in the same area the mechanical strain without thermal strain (i. e. the mechanical strain discriminated).

## 4.3 Area A: Sensors Configuration And Relative Technological Objectives

The area A corresponds to a panel between the frame 14-15 and the stringers 10-11 on the left side of the aircraft respect to the flight direction. This is a free panel on the external and internal side and for this reason has been decided to verify a FOBG thermal strain discrimination other than FOBG sensors efficiency.

To execute this verification, the sensors applied in this area are the following:

- 2 RFOBG back to back on internal and external side of aircraft
- 2 FOBG only dedicated to the thermal strain on internal and external side of aircraft
- 1 RSG on internal side of aircraft very close to the internal RFOBG to verify, by comparison, the

**Alenia SHM Fiber Optic Bragg Grating (FOBG)  
Strain Sensors Technology: Applications and Requirements**

efficiency of the three FOBG sensors in the directions a, b, c.

The application of these sensors is shown in the figure 7.

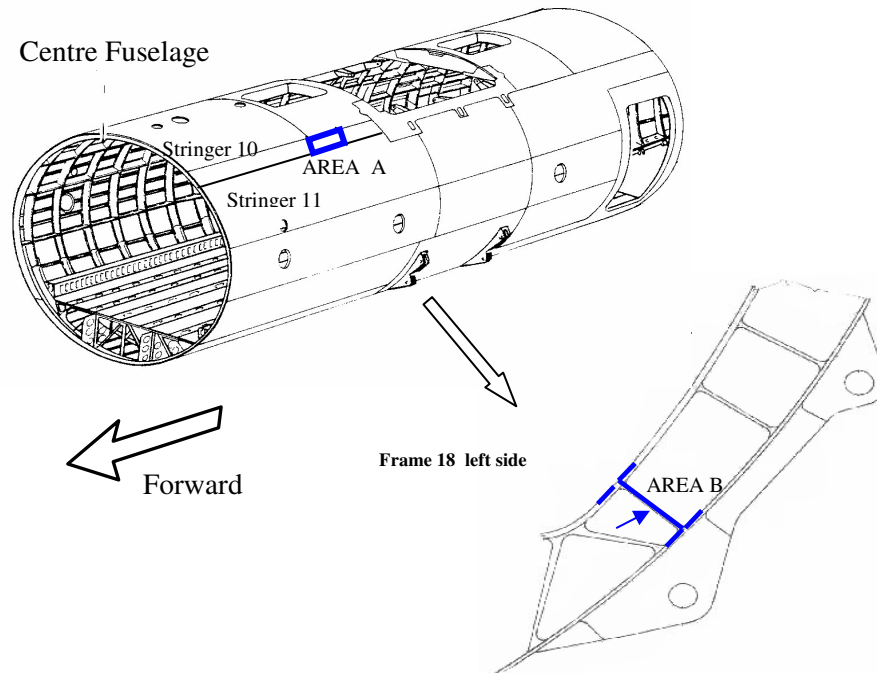

**Figure 5 – Area of interest for the FOBG sensors application**

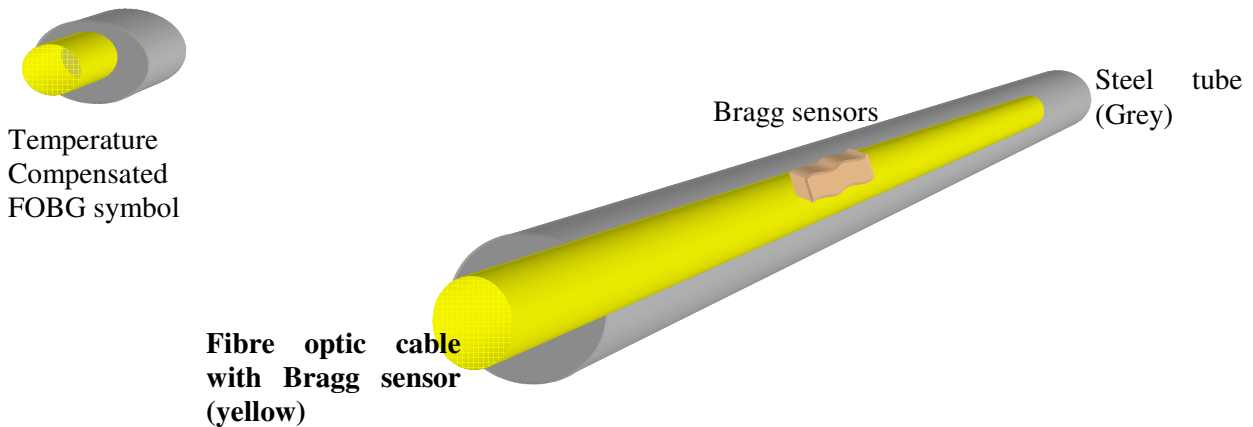

**Figure 6 - Scheme and symbol of FOBG sensor dedicated only to the thermal strain**



The 3 external FOBG sensors will be bonded on the whole path on the external fuselage. The capillary steel tube will be bonded on the whole path on the external fuselage.

The fibre optic sensor dedicated to the thermal strain will be bonded on the fuselage at the end of capillary steel tube (the section of this fibre optic including the grating sensor placed inside to the capillary steel tube is free to float).

The 4 fibre optic cables before (10 cm) to enter inside of aircraft will be bundle together.

The entry point to the aircraft will be made through the upper fuselage forward wing trap door. In the figure 7a) the external cable path of the 4 sensors is shown. After thrown through the trap door, i.e. internal to the aircraft, these 4 fibre optic cables will be connected to a 1 x 4 coupler element in order that one cable only continue up to the interrogation equipment. In the figure 7b) the positioning of the other involved internal sensors is shown. Also these internal fibre optic cables will be connected to the 1x4 coupler element in order to minimise the number of the cables inside the aircraft.

In this area are expected tensile/compression state and shear stress due to the pressurization effect: this skin will deform for the pressure difference between internal and external side of aircraft. The mechanical strain values are foreseen up to a maximum of 1100 microstrain.

A local FEM model relative to the behaviour of the area A will be developed in order to allow a theoretical prevision to be compared with the experimental measure.

Summarising for this area A, the technological objectives are:

- assess and verify the maturity level of the FOBG technology comparing the theoretical FEM prevision with the results of three branches of RFOBG (temperature compensated by means the dedicated internal FOBG) and RSG (that already execute the temperature compensation) on the internal side of aircraft;
- verify the discrimination mechanical/thermal strain efficiency comparing the results between the three branches of the two RFOBG back to back on the external and internal side (where the temperature will be different).

#### **4.4 Area B: Sensors Configuration And Relative Technological Objectives**

Area B corresponds to an internal sector to the aircraft in correspondence of the left forward lower Lug and precisely the double T shape enhanced in blue in the figure 5; so in this case there are not external sensors. The area where the sensors will be applied is shown in the figure 8 (the area corresponds to the sector indicated by the blue arrow in figure 5). The sensors applied in the area B are the following:

- 1 RFOBG very close to 1 RSG to verify, by comparison, the efficiency of the three FOBG sensors in the directions a, b, c;
- 1 FOBG dedicated only to the thermal strain on internal side of aircraft;
- two couples axial SG/FOBG sensors.

The RSG and the three branches of the RFOBG (with the correspondent branches in parallel direction) will be bonded the closest possible like shown in the figure 8 and also the dedicated thermal strain FOBG is placed very close in the same area. The two couples constituted by an axial SG and a FOBG placed at a maximum distance of 1 cm, will be bonded in the positions as shown in the figure 8. Tensile or compression stress are expected in the sector where the axial SG and FOBG are applied, while on the panel where the RSG and RFOBG are applied, tensile/compression state and shear stress are expected: **there will be two main moments relative to the activation of landing gear during the take off (closure) and landing phase (deployment); during the flight phase the pressurization effect due to the pressure difference between internal and external side of aircraft will be the main phenomenon.**

Concerning these phases, a local FEM model relative to the behaviour of the area B will be developed in order to allow a theoretical prevision to be compared with the experimental measure.

In this case the technological objective is to assess and verify:

- the maturity level of the FOBG technology comparing the results of three branches of RFOBG (temperature compensated by means the dedicated internal FOBG) and the close RSG (that already execute the temperature compensation) in the same area and, furthermore, other two results comparison between FOBG and axial SG will be performed;

**Alenia SHM Fiber Optic Bragg Grating (FOBG)  
Strain Sensors Technology: Applications and Requirements**

- the efficiency of thermal strain discrimination.

a) external view

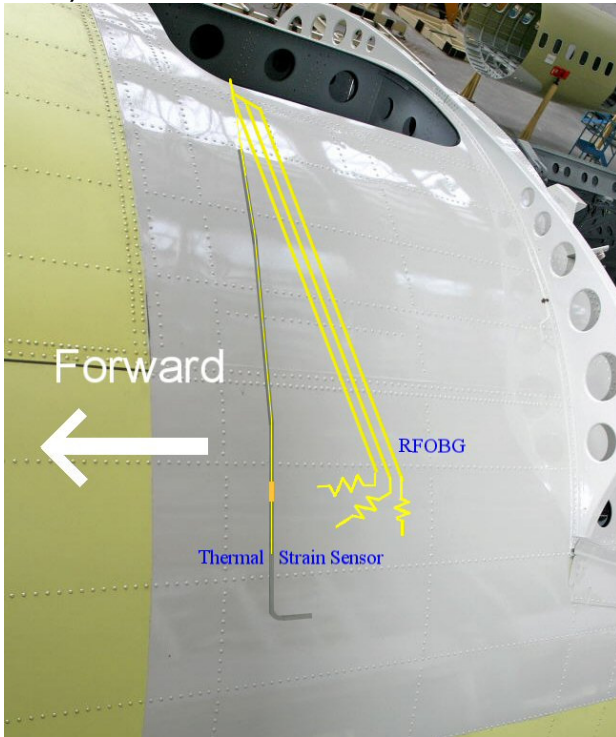

b) internal view

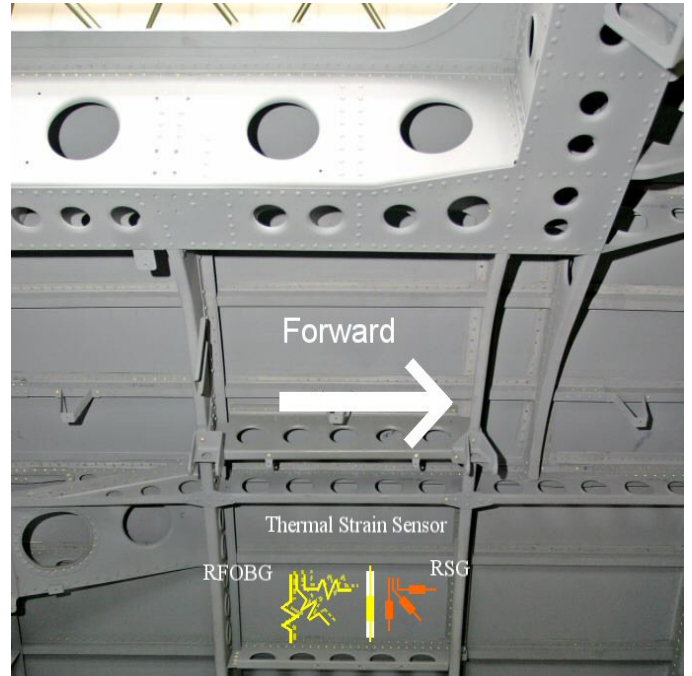

**Figure 7 - Area A: Placement and Path of sensors**

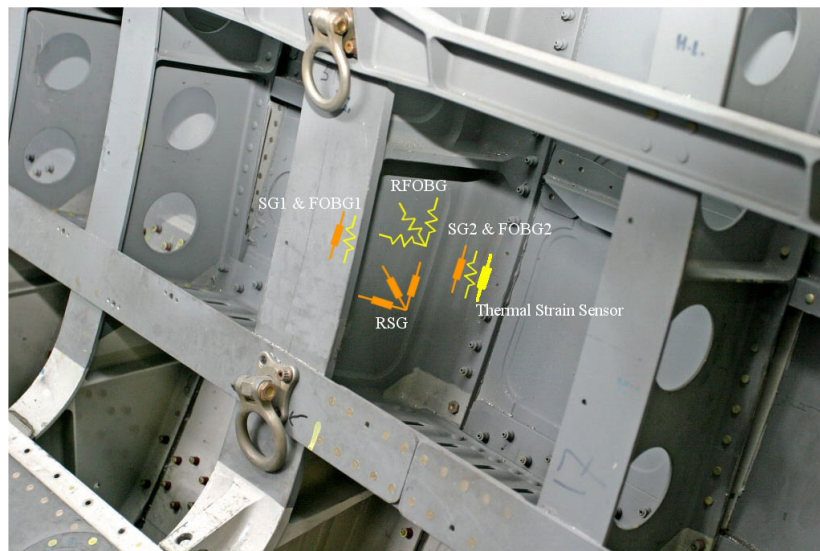

**Figure 8 - Area B: sensors configuration**

**SYMPOSIA DISCUSSION – PAPER NO: 7**

**Author's Name:** F.P. Camerlingo

**Question (C. Cesnik):**

How the external fibers applied in area A get into the aircraft?

**Author's Response:**

A modified inspection window with a tube is used to bring the external fiber into the aircraft.

**Alenia SHM Fiber Optic Bragg Grating (FOBG)  
Strain Sensors Technology: Applications and Requirements**

---

